

MO6-4.5 6V4.5Ah

Specifications

Nominal Voltage	6V	
Rated capacity (20 hour rate)	4.5Ah	
Dimensions	Length	70±1mm(2.76inch)
	Width	48±1mm(1.89inch)
	Height	101±1mm(3.98inch)
	Total Height	107±1mm(4.21inch)
Approx. Weight	0.76kg(1.68lbs)±5%	

Outer dimensions (mm)

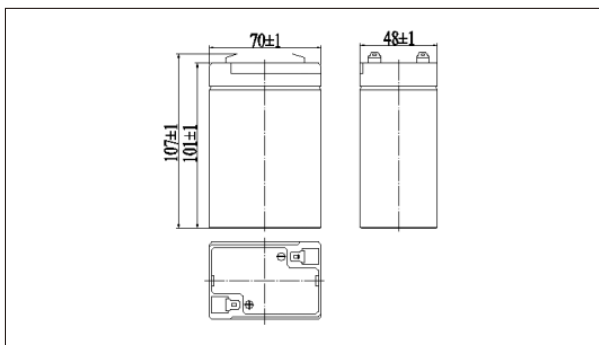

Terminal Type (mm)

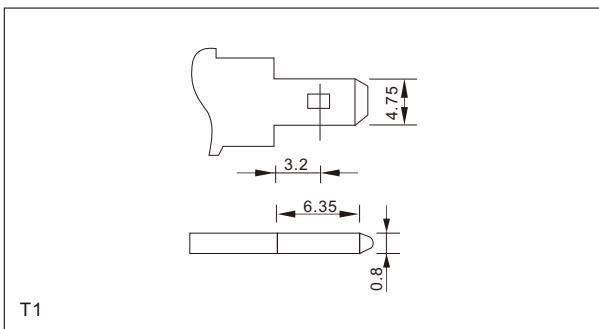

Characteristics

Capacity (25°C)	20HR(3.50V)	4.5Ah
	10HR(3.50V)	4.2Ah
	1HR(3.20V)	2.7Ah
Terminal type		T1
Internal resistance (Fully charged, 25°C)		Approx. 18mΩ
Capacity affected by temperature (20HR)	40°C	102%
	25°C	100%
	0°C	85%
	-15°C	65%
Self-discharge (25°C)	3 months	Remaining Capacity: 91%
	6 months	Remaining Capacity: 82%
	12 months	Remaining Capacity: 65%
Nominal operating temperature		25°C ± 3°C (77°F ± 5°F)
Operating temperature range	Discharge	-15°C ~ 50°C (5°F ~ 122°F)
	Charge	-10°C ~ 50°C (14°F ~ 122°F)
	Storage	-20°C ~ 50°C (-4°F ~ 122°F)
Float charging voltage (25°C)		6.75 to 6.90V Temperature compensation: -9mV/°C
Cyclic charging voltage (25°C)		7.25 to 7.50V Temperature compensation: -15mV/°C
Maximum charging current		1.35A
Maximum discharge current		68A(5 sec.)
Designed floating life (20°C)		5 years

Construction

Component	Positive plate	Negative plate	Container	Cover	Separator	Electrolyte	Safety valve	Terminal
Raw material	Lead dioxide	Lead	ABS	ABS	AGM	Sulfuric acid	Rubber	Copper

Constant Current Discharge Characteristics Unit: A(25°C, 77°F)

F.V/Time	5min	10min	15min	30min	60min	2h	3h	4h	5h	10h	20h
4.80V	17.2	10.9	8.51	4.79	2.95	1.61	1.12	0.92	0.78	0.43	0.23
4.95V	16.7	10.6	8.30	4.70	2.90	1.60	1.11	0.92	0.78	0.42	0.23
5.10V	16.0	10.1	7.99	4.55	2.83	1.59	1.10	0.91	0.77	0.42	0.23
5.25V	15.3	9.69	7.72	4.44	2.77	1.56	1.09	0.90	0.77	0.42	0.23
5.40V	14.4	9.15	7.31	4.28	2.69	1.52	1.06	0.88	0.75	0.41	0.22

Constant Power Discharge Characteristics Unit: W(25°C, 77°F)

F.V/Time	5min	10min	15min	30min	60min	2h	3h	4h	5h	10h	20h
4.80V	95.9	61.4	48.5	27.5	17.1	9.43	6.63	5.49	4.69	2.56	1.37
4.95V	93.0	59.4	47.3	26.9	16.8	9.38	6.59	5.46	4.66	2.55	1.36
5.10V	89.2	57.1	45.6	26.1	16.4	9.29	6.54	5.42	4.63	2.53	1.36
5.25V	85.4	54.7	44.0	25.5	16.1	9.15	6.50	5.39	4.59	2.52	1.35
5.40V	80.6	51.6	41.7	24.5	15.6	8.92	6.30	5.22	4.46	2.47	1.32

Note: The above characteristics data can be obtained within three charge or discharge cycles.

MO6-4.5 6V4.5Ah

Discharge characteristics(25°C)

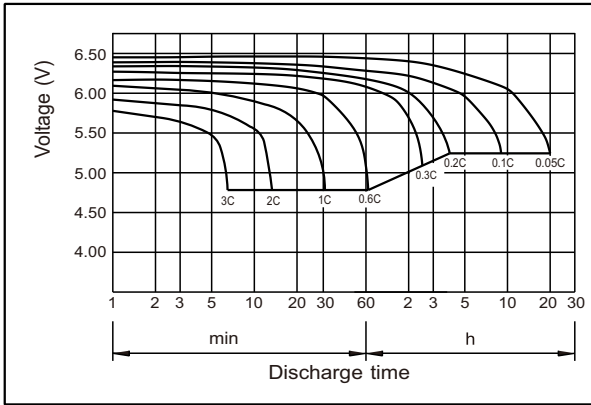

Charging characteristics (25°C)

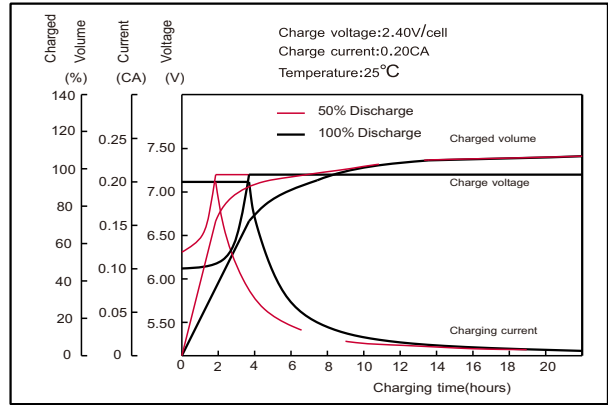

Effect of temperature on capacity

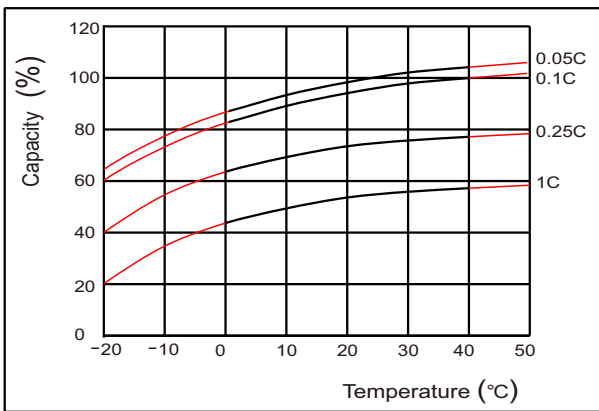

Self-discharge characteristics

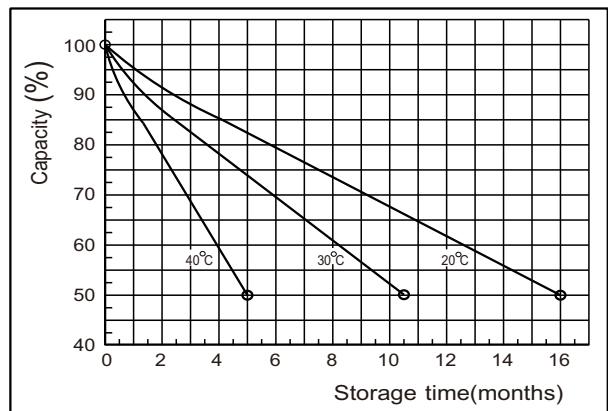

Floating life on temperature

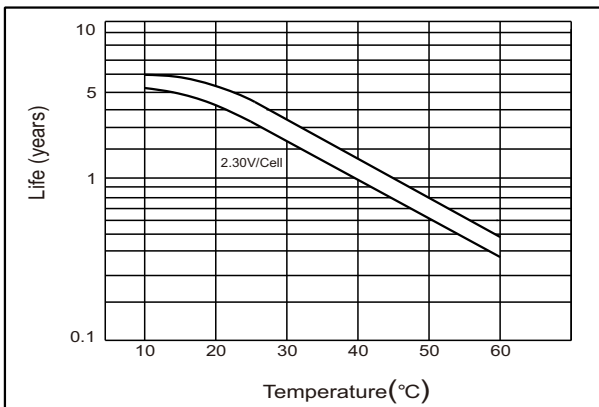

Cycle life on D.O.D(25°C)

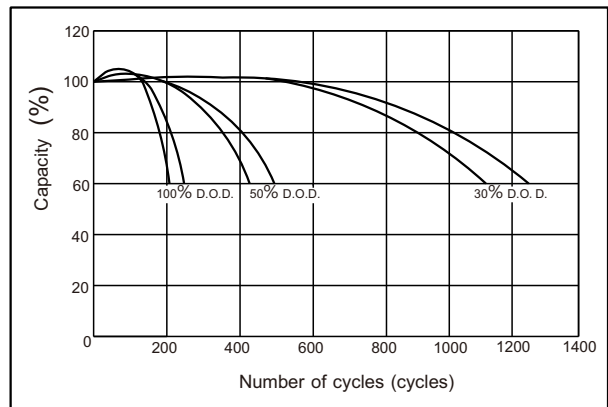

The relationship for OCV and Capacity (25°C)

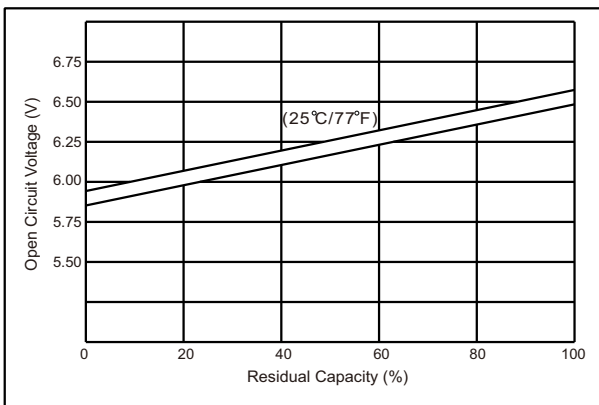

The relationship for Charging voltage and Temperature

